

# EXAR Power Management Solutions for Actel IGLOO®, ProASIC®3 and Fusion FPGA Devices



powered by



because Power Matters

## Need Market-Proven Power Management Solutions for Your Low-Power FPGA Designs?

Targeting Point-of-Load applications requiring:

- Small packages + low external component count
- Highest efficiency at all load conditions
- Low quiescent/shutdown current
- Dynamically selectable output voltage
- Flexible and reprogrammable solutions

See how Exar's **Step down Regulators** can get your designs to market faster.  
Ask our Application Engineers!

Product	V <sub>CC</sub> Core Voltage	V <sub>CCI</sub> I/O Voltage	V <sub>JTAG</sub> JTAG I/O voltage	V <sub>PUMP</sub> Programming Voltage	V <sub>CCPLL</sub> PLL Supply Voltage
IGLOO/e	1.2-1.5V*	1.2-3.3V	1.5-3.3V	3.3V	1.2-1.5V
IGLOO nano	1.2-1.5V*	1.2-3.3V	1.5-3.3V	3.3V	1.2-1.5V
IGLOO PLUS	1.2-1.5V*	1.2-3.3V	1.5-3.3V	3.3V	1.2-1.5V
ProASIC3/E	1.5V	1.5-3.3V	1.5-3.3V	3.3V	1.5V
ProASIC3 nano	1.5V	1.5-3.3V	1.5-3.3V	3.3V	1.5V
ProASIC3L	1.2-1.5V*	1.2-3.3V	1.5-3.3V	3.3V	1.2-1.5V
Fusion	1.5V	1.5-3.3V	1.5-3.3V	3.3V	1.5V

\* 1.5V Core Voltage needed during programming

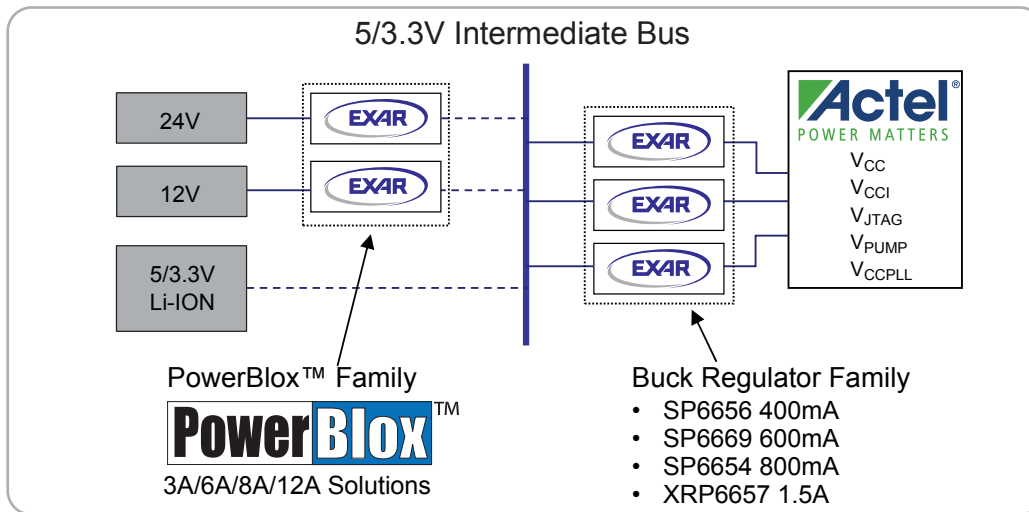

Exar's online power simulator and design tool

**Power Lab™**  
power design made easy

<http://www.exar.com/powerlab>

[www.exar.com](http://www.exar.com)



## SP6656

- Up to 98% efficiency
- Small DFN package (2.4x2.5mm)
- Delivers up to 400mA of continuous current
- Low quiescent (20µA)/shutdown (1nA) current
- Dynamically adjustable output
  - IGLOO and ProASIC3L require 1.5V core voltage for programming when running at 1.2V during normal operation

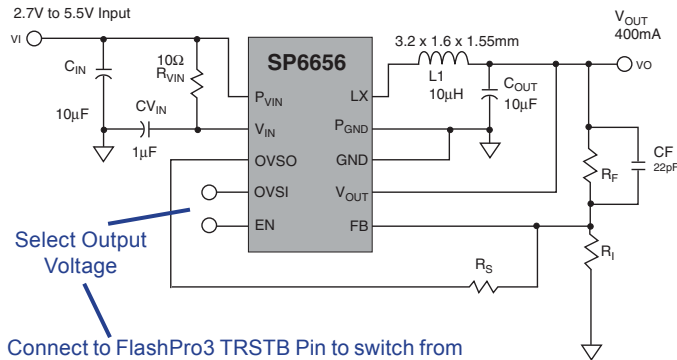

Select Output Voltage  
Connect to FlashPro3 TRSTB Pin to switch from 1.2V to 1.5V during Programming

## XRP6657

- Up to 95% efficiency
- Small DFN package (3x3mm)
- Delivers up to 1.5A of continuous current
- Low quiescent (240µA)/shutdown (.1µA) current
- Lowest external component count

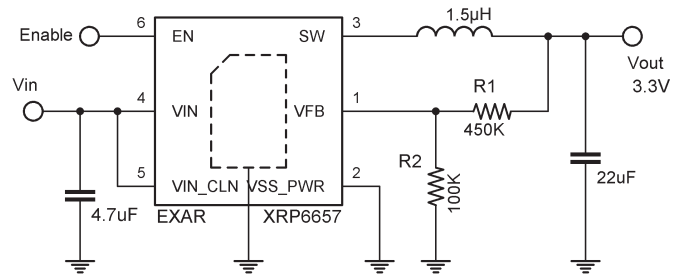

### Buck Regulator Family

Part Number	I <sub>OUT</sub>	V <sub>IN</sub> Min	V <sub>IN</sub> Max	I <sub>Q</sub>	Fixed Outputs	Output Range	Freq.	Efficiency	Package	Special Features
SP6656	400mA	2.7V	5.5V	20µA	Adj.	0.8V to 5V	PFM	98%	10-Pin DFN	Dynamically selectable output voltage.
SP6669	600mA	2.5V	5.5V	200µA	Yes	0.6V to 5V	1.5MHz	95%	5-Pin SOT-23	Adjustable 1.2V, 1.5V, and 1.8V outputs. Pulse skipping at light load for improved efficiency
SP6654	800mA	2.7V	5.5V	20µA	Adj.	0.8V to 5V	PFM	98%	10-Pin DFN 10-Pin MSOP	Logic level shutdown, digitally programmable UVLO threshold, power good indicator.
XRP6657*	1.5A	2.5V	5.5V	240µA	Adj.	0.6V to 5V	1.3MHz	95%	6-Pin DFN	Adjustable output, pulse skipping at light load for improved efficiency.

\*coming soon

### PowerBlox Family

Part Number	I <sub>OUT</sub>	MOSFET RDS(ON) mΩ		V <sub>IN</sub> (V)		Ref Voltage	Accuracy	Frequency	Efficiency	Fault Protection
		High Side	Low Side	Min	Max					
SP7656	3A	60	n/a	4.5	29	0.6V	±1%	600kHz	89%	OCP
SP7650	3A	40	40	2.5	28	0.8V	±1%	300kHz	95%	UVP
SP7661	3A	75	75	3.0/5.5	22	0.8V	±1%	600kHz	92%	UVP, OCP
SP7651	3A	40	40	2.5	20	0.8V	±1%	900kHz	92%	UVP
SP7653	3A	40	40	2.5	20	0.8V	±1%	1.3MHz	91%	UVP
SP7652	6A	15	15	2.5	28	0.8V	±1%	600kHz	92%	UVP
SP7663	6A	17	17	3.0/5.5	22	0.8V	±1%	600kHz	91%	UVP, OCP
SP7655	8A	15	15	2.5	28	0.8V	±1%	300kHz	95%	UVP
SP7662	12A	17	7	3.0/5.5	22	0.8V	±1%	300kHz	93%	UVP, OCP

EXAR's product portfolio also contains low-power LDO's which can be used for FPGA power supplies. Please check our web site and/or our Power Management brochure.

www.exar.com

