

REVISION HISTORY			
REV	DESCRIPTION	DATE	APP'D
A	DRAWING ORIGINATOR	08/18/05	JL
B	MODIFY DRAWING FORMAT	07/17/06	JL
C	ADD LAND PATTERN RECOMMENDATION	12/07/06	JL
D	CHANGE DRAWING LOGO AND COMPANY NAME	11/21/07	JL

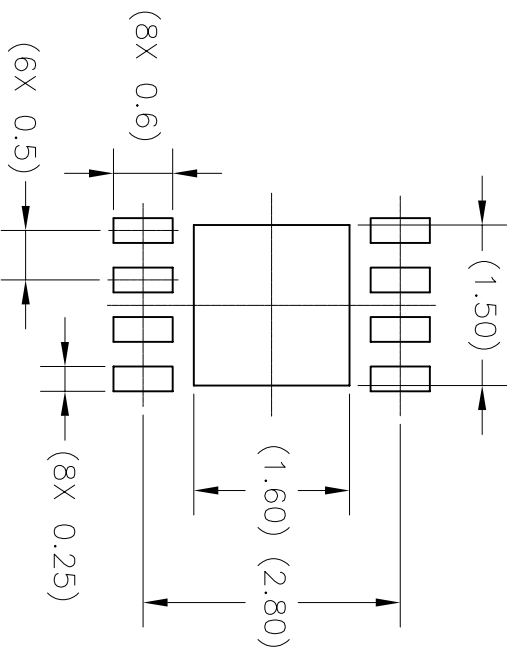
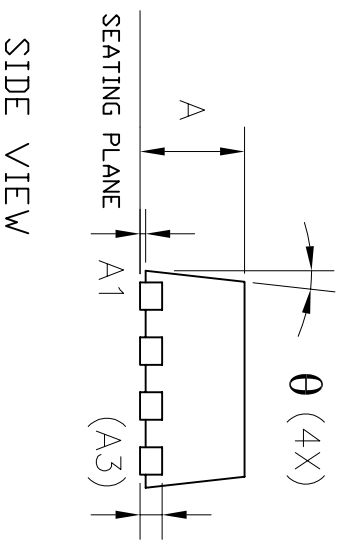
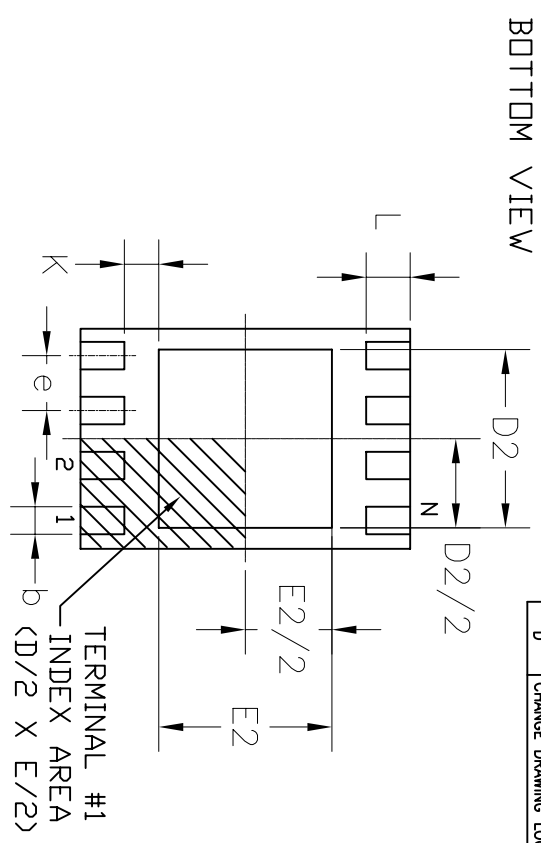
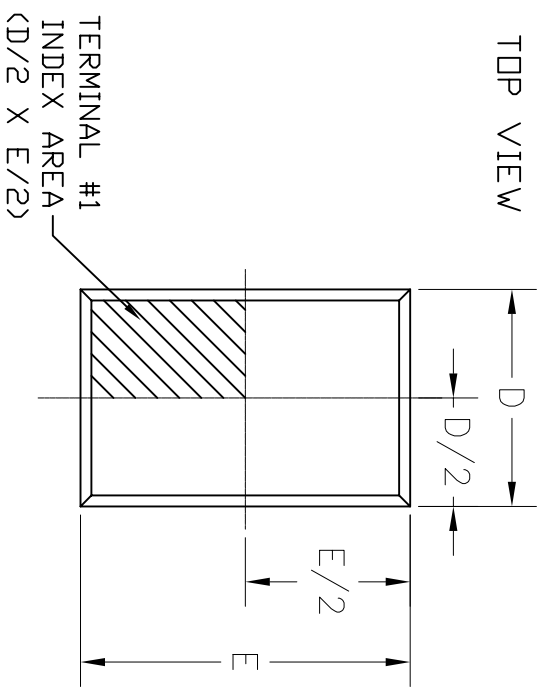

8LD 2x3 DFN JEDEC MO-229 Variation VCEd-2						
SYMBOLS	DIMENSIONS IN MM (Control Unit)	DIMENSIONS IN INCH (Reference Unit)				
	MIN	NOM	MAX	MIN	NOM	MAX
A	0.80	0.90	1.00	0.032	0.036	0.039
A1	0.00	0.02	0.05	0.000	0.001	0.002
A3	0.20 REF		0.008 REF			
b	0.18	0.25	0.30	0.007	0.010	0.012
D	2.00 BSC		0.079 BSC			
D2	1.50	—	1.75	0.059	—	0.069
E	3.00 BSC		0.118 BSC			
E2	1.60	—	1.90	0.063	—	0.075
e	0.50 BSC		0.020 BSC			
L	0.30	0.40	0.50	0.012	0.016	0.020
K	0.20	—	—	0.008	—	—
theta	0°	—	14°	0°	—	14°
N	8		8			
ND	4		4			

LAND PATTERN RECOMMENDATION

		EXAR CORPORATION	
Packaging Approval:		Drawing No: 8-PIN 2x3 DFN	
By: JL	Date: 11/21/07	Revision: D	Sheet: 1 OF 1