

## Complete Backlight Solution

### FEATURES

- Complete Backlight Solution
- Separate control for 4 main, 2 sub, and keypad LEDs
- Built-in 6-bit DAC for precise current setting
- I<sup>2</sup>C serial interface
- Data is stored in shutdown
- 1x and 1.5x mode operation with automatic switchover
- Very low dropout: 200mV typ
- Very low 31μA current (LSB)
- 2MHz switching frequency reduces external components
- Power-saving shutdown mode of 1μA
- Built-in over-temperature protection
- Available in Lead Free, RoHS compliant package:  
Small 16-pin 3x3 QFN

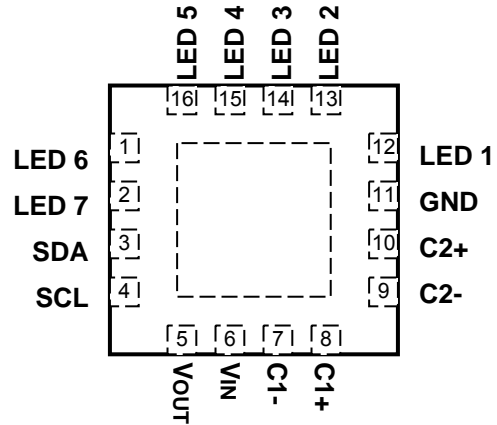

### DESCRIPTION

The SP7680 is a complete backlight display solution that is designed to independently control LEDs for main and auxiliary displays as well as the keypad. A two line I<sup>2</sup>C serial interface allows a simple way to adjust each current individually in order to provide ultimate flexibility in driving LEDs. The data is loaded into internal registers upon power up and stored while in shutdown. When the chip is enabled the stored values set the LED currents. Extra low 33μA LSB allows trickle current through the LEDs for non-reflecting LCD displays. The SP7680 automatically detects 1x or 1.5x operation for optimal efficiency.

### TYPICAL APPLICATION CIRCUIT

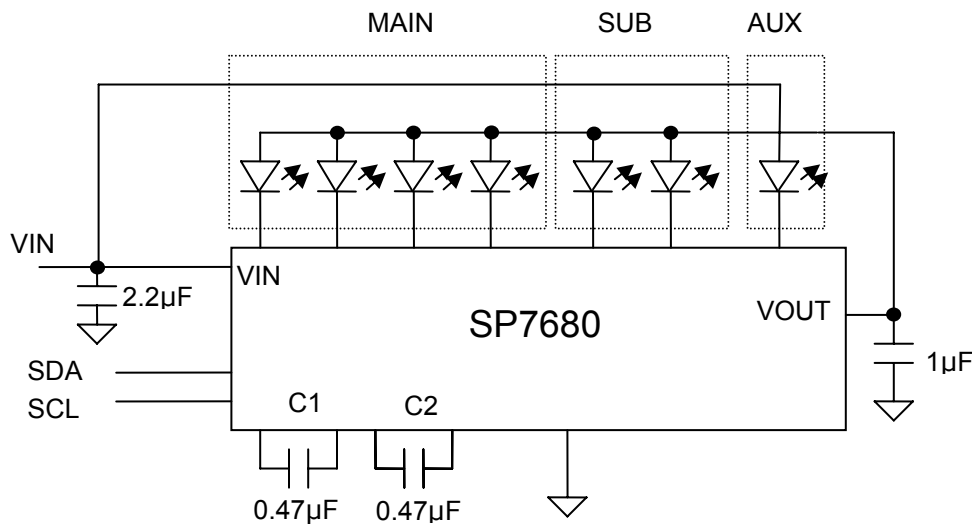

## ABSOLUTE MAXIMUM RATINGS

These are stress ratings only and functional operation of the device at these ratings or any other above those indicated in the operation sections of the specifications below is not implied. Exposure to absolute maximum rating conditions for extended periods of time may affect reliability.

VIN, SDA, SCL, LEDx, VOUT.....-0.3V to 6.0V	Junction Temperature
Power Dissipation ..... Internally limited	(TJ = TA + PD•33.3°C/W)..... 40°C to +125°C
Storage Temperature.....-65°C to 150°C	ΘJA (1 square 1oz Cu).....33.3°C/W

## ELECTRICAL SPECIFICATIONS

Unless otherwise specified: VIN= 2.7V-5.5V, CIN = 2.2μF, COUT = 1μF, CFL2 = 0.47μF, CFL2 = 0.47μF, TA = -40°C to +85°C, Tj=-40°C to +125°C. **Bold** values apply over the full operating temperature range.

PARAMETER	MIN	TYP	MAX	UNITS	CONDITIONS
Operating Input Voltage Range	<b>2.7</b>		<b>5.5</b>	V	
Operating Input Current (4 MAIN LEDs operating at 33uA each, all other LEDs off, in 1X mode)		300	<b>400</b>	μA	VIN=4.0V, VLED = 3.3V Status = 11000000 CNTRL = 00011110 Main=Sub=Aux=00000000
Operating Input Current (Charge pump in 1.5X mode with all LEDs at 33uA each)		5	<b>8</b>	mA	VIN = 3.0V, VLED = 3.3V Status = 11000000 CNTRL = 11111110 Main=Sub=Aux=00000001
Standby mode Quiescent Current		200	<b>300</b>	μA	Vin=4.0V Status = 10000000 CNTRL = 00000000 Main=Sub=Aux=00000000
Maximum Output Current (Note 1)		200		mA	VIN = 3.4V, VLED = 3.3V
LED Current accuracy	<b>-10</b>		<b>10</b>	%	ILED = 20mA
LED Current matching	<b>-3</b>		<b>+3</b>	%	ILED = 20mA
Current DAC Resolution		6		bits	
Current for DAC=000000		0		mA	
Current for DAC=000001	<b>5</b>	31	<b>50</b>	μA	1x mode only
Current DAC LSB DAC=00010		1		mA	MAIN and SUB LEDs
Current DAC LSB DAC=00010		2		mA	AUX LED
LED Dropout Voltage (Note 2)			<b>0.2</b>	V	ILED =20mA for MAIN and SUB; ILED =40mA for AUX
Maximum LED Current		31.5		mA	After 63 counts MAIN and SUB LEDs
Maximum LED Current		63		mA	After 63 counts AUX LED
Switching Frequency	<b>1.6</b>	2	<b>2.4</b>	MHz	
Equivalent Resistance, 1x mode		3	<b>5</b>	Ω	VIN=3.4V
Equivalent Resistance, 1.5x mode		6	<b>10</b>	Ω	VIN=3.4V
Control Clock Frequency			<b>0.4</b>	MHz	

**ELECTRICAL SPECIFICATIONS continued**

PARAMETER	MIN	TYP	MAX	UNITS	CONDITIONS
Power-up time from Shutdown (Note 3)		1.5	2	ms	V <sub>IN</sub> = 4.2V, V <sub>LED</sub> =3.3V Initial State: Status = 00000000 Final State: Status = 11000000 CNTRL = 11111110  Main=Sub=Aux=00000000 Time measured from stop bit of final state I <sup>2</sup> C command to point where V <sub>OUT</sub> = 4.1V
Soft Start Interval (within 1X mode) (Note 4)		5		μs	V <sub>IN</sub> = 4.0V, V <sub>LED</sub> =3.3V Initial State: Status = 11000000 CNTRL = 11111110  Main=Sub=Aux=00000000 Final State: Status = 11000000 CNTRL = 11111110  Main=Sub=Aux=11111100 Time measured from the raising edge of STATUS acknowledge bit of final state command to the point where all current is within 5% of its final value.
Soft Start Interval (transition 1X to 1.5X) (Note 5)		140		μs	V <sub>IN</sub> = 3.4V, V <sub>LED</sub> = 3.3V Initial State: Status = 11000000 CNTRL = 11111110  Main=Sub=Aux=00000000 Final State: Status = 11000000 CNTRL = 11111110  Main=Sub=Aux=11111100 Time measured from the raising edge of CNTRL acknowledge bit of final state command to the point where output voltage is within 5% of its final value.
Shutdown Supply Current @ 25 °C		0.01	2	μA	If both SDA and SCL are low for 50ms, the part goes into shutdown mode, set STATUS=00000000, V <sub>SUPPLY</sub> = 4.2V
Shutdown Supply Current @ 85 °C			5	μA	If both SDA and SCL are low for 50ms, part goes into shutdown mode set STATUS=00000000, V <sub>SUPPLY</sub> = 4.2V
Short LED threshold		V <sub>OUT</sub> - 0.5V	V <sub>OUT</sub> - 1V		
Thermal Shutdown Die Temperature		170		°C	Regulator turns off
Thermal Shutdown Hysteresis		25		°C	Regulator turns on again @ 150°C
SDA, SCL low timeout	50	65		ms	If both SDA and SCL are low for 50ms, part goes into shutdown mode set STATUS=00000000
SDA, SCL input logic low voltage			0.4	V	Regulator shutdown
SDL, SCA input logic high voltage	1.6			V	Regulator enabled

**Note 1:** The maximum output current is a derived spec  $I_{OUTMAX} = (V_{IN} * 1.5 - V_{LED} - V_{DROPOUT}) / (\text{max Req } 1.5X \text{ mode})$ .

**Note 2:** Dropout is defined when LED current goes 10% below nominal value as V<sub>IN</sub> is lowered.

Note 3: Power-up time from Shutdown

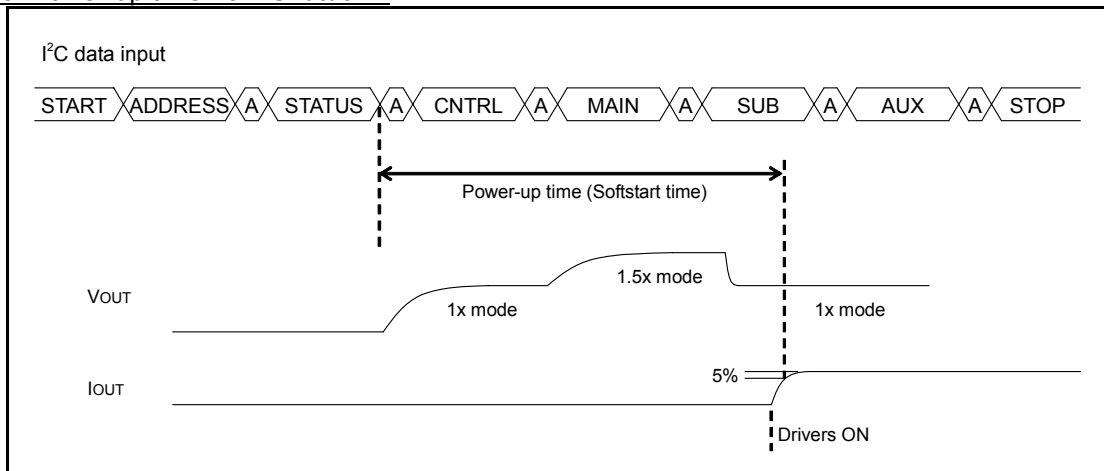

Note 4: Soft Start Interval (within 1x Mode)

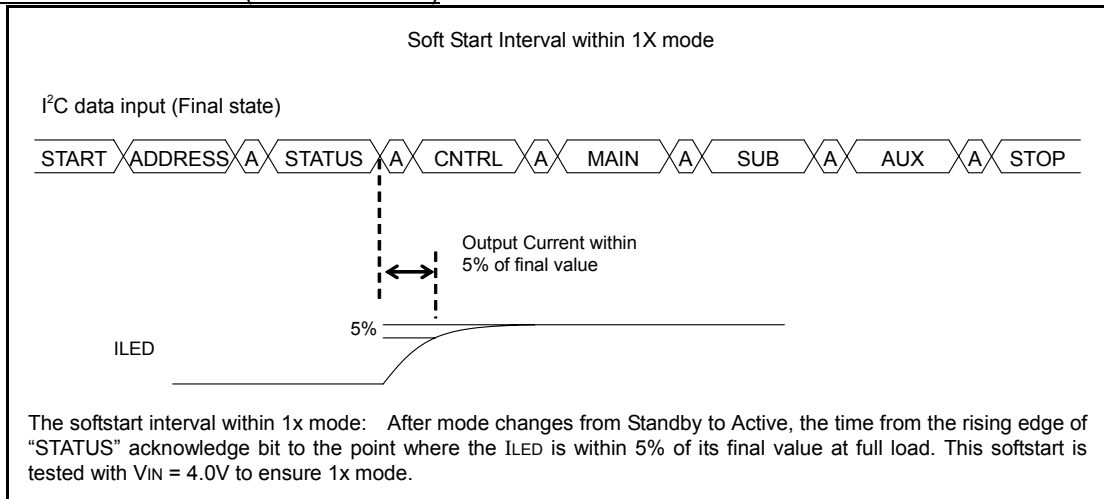

Note 5: Soft Start Interval (Transition 1x to 1.5x Mode)

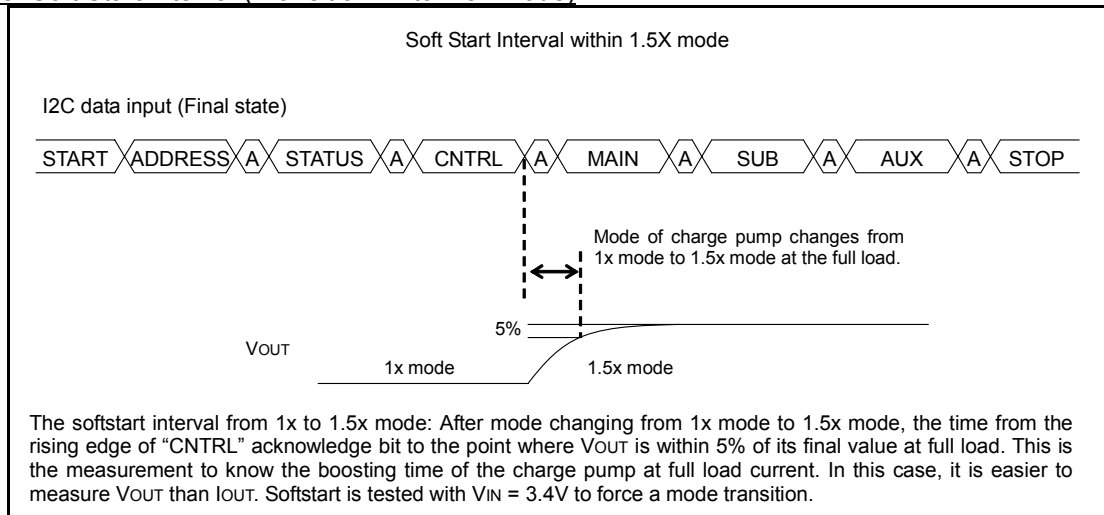

## TIMING CHARACTERISTICS

(Typical Operating Circuit,  $V_{IN} = 2.7V$  to  $5.5V$ ,  $T_J = -40^{\circ}C$  to  $125^{\circ}C$ , unless otherwise noted. Typical Values are at  $V_{IN} = 3.3V$ ,  $T_A = +25^{\circ}C$ )

PARAMETER	SYMBOL	CONDITIONS	MIN	TYP	MAX	UNITS
Serial Clock Frequency	$f_{SCL}$			400		kHz
Bus Free Time Between a STOP and a START	$t_{BUF}$		1.3			$\mu s$
Hold Time, Repeated START Condition	$t_{HD\_STA}$		0.6			$\mu s$
Repeated START Condition Setup Time	$T_{SU,STA}$		0.6			$\mu s$
STOP Condition Setup Time	$t_{SU,STO}$		0.6			$\mu s$
Data Hold Time	$t_{HD,DAT(OUT)}$		225		900	ns
Input Data Hold Time	$t_{HD,DAT(IN)}$		0		900	ns
Data Setup Time	$t_{SU,DAT}$		100			ns
SCL Clock Low Period	$t_{LOW}$		1.3			$\mu s$
SCL Clock High Period	$t_{HIGH}$		0.6			$\mu s$
Rise Time of Both SDA and SCL Signals, receiving	$t_R$	(Notes2, 3)	20+		300	ns
Fall Time of Both SDA and SCL Signals, Receiving	$t_F$	(Note2, 3)	20+		300	ns
Fall Time of SDA Transmitting	$t_{F, TX}$	(Note2, 3, 4)	20+		250	ns
Pulse Width of Spike Suppressed	$t_{SP}$	(Note5)	0		50	ns
Capacitive Load for Each Bus Line	$C_b$	(Note 2)	400			pF
I <sup>2</sup> C startup time after UVLO clears	$T_{srt}$	(Note 2)	1			$\mu s$

Note 1: All parameters tested at  $T_A = 25^{\circ}C$ . Specifications over temperature are guaranteed by design.

Note 2: Guaranteed by design.

Note 3:  $C_b$  = total capacitance of one bus line in pF.  $t_R$  and  $t_F$  measured between  $0.3 \times V_{DD}$  and  $0.7 \times V_{DD}$ .

Note 4:  $I_{SINK} \leq 6mA$ .  $C_b$  =total capacitance of one bus line in pF.  $t_R$  and  $t_F$  measured between  $0.3 \times V_{DD}$  and  $0.7 \times V_{DD}$ .

Note 5: Input filters on the SDA and SCL inputs suppress noise spikes less than 50ns.

## PIN DESCRIPTION

PIN #	PIN NAME	DESCRIPTION
6	V <sub>IN</sub>	Input voltage for the regulator. Connect a 2.2μF decoupling capacitor between this pin and ground.
12-16 1,2	LED1-LED 5 LED6,LED7	Connect an LED between each pin and V <sub>OUT</sub> . Current value is controlled by the serial interface. The current level through each pin is internally matched within 3%. This current value can be programmed to any level for MAIN or SUB LEDs with 0.5mA step (64 steps total). Voltage at these pins is internally monitored to control the switching between 1x and 1.5x mode in order to ensure the best possible efficiency.
5	V <sub>OUT</sub>	Output of the charge pump. Place a 1μF decoupling capacitor from this pin to ground. This voltage is regulated by the 1x or 1.5x charge pump to create voltage sufficient to operate the current sources.
11	GND	Ground pin.
3,4	SDA,SCL	Clock and data inputs for I <sup>2</sup> C interface. Connect a 100KΩ pull-up to V <sub>IN</sub> or V <sub>CC</sub> .
7,8	C1-, C1+	Connect 0.47μF ceramic capacitor between these pins.
9,10	C2-, C2+	Connect 0.47μF ceramic capacitor between these pins.
-	Thermal Pad	Connect to GND.

## SP7680 FUNCTIONAL DIAGRAM

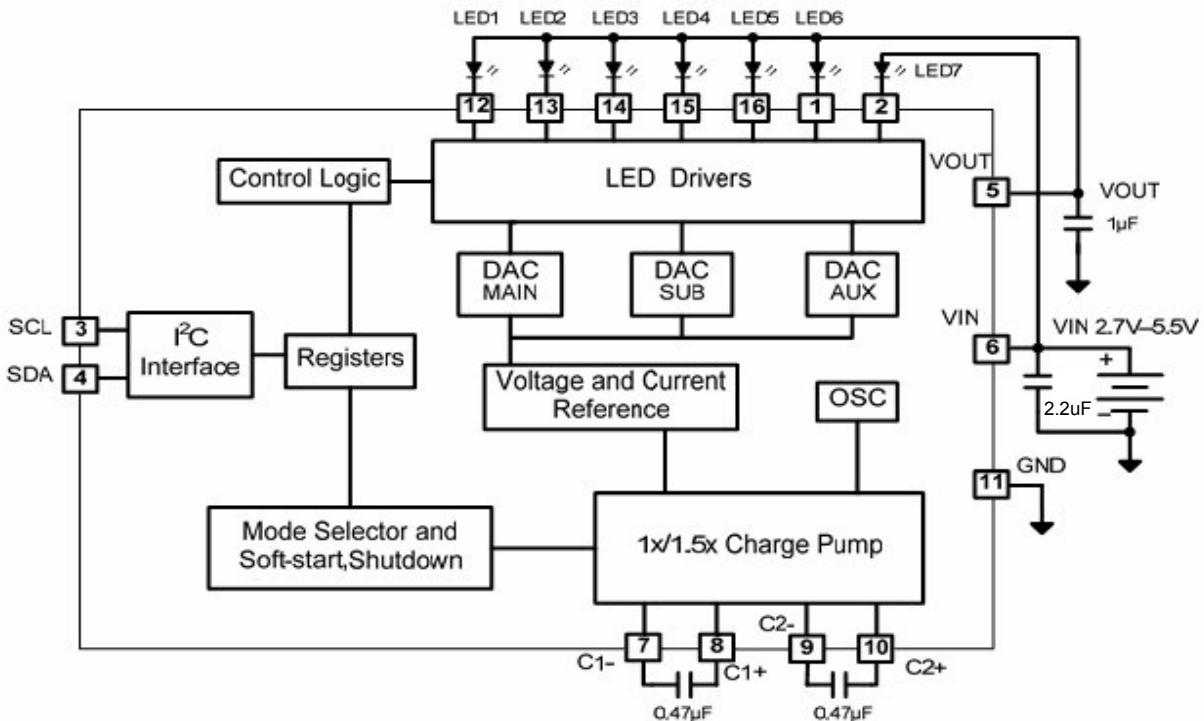

The SP7680 is a charge pump regulator designed for converting an input voltage of 2.7V to 5.5V to drive backlight white LEDs used in portable applications. It has a total of 7 LED driver outputs consisting of 4 Main, 2 Sub and one Auxiliary keypad output. The Main and Sub outputs can drive up to 31.5mA for each LED while the Aux output can drive up to 63mA. With the I<sup>2</sup>C serial interface, each LED can be turned on/off independently so any combination of 7 outputs is available. Three 6-bit DACs are included to provide precise current level setting. The drive current is set simultaneously for one group. The brightness integrity and good current matching among channels are assured by this control method.

The SP7680 is a fractional charge pump and can multiply the input voltage by 1 or 1.5 times. The charge pump switches at a high fixed frequency of 2MHz which allows for reduced external component sizes. The internal mode selection circuit automatically switches the mode between 1x and 1.5x mode based on the input voltage, output voltage and load current. This mode switching maximizes the efficiency throughout the entire load range. When the battery voltage is high enough, the SP7680 operates in 1x mode to provide maximum efficiency. Dropout detection is provided on all four MAIN LED outputs and the two SUB LED outputs, to determine when the SP7680 needs to transition to 1.5X mode. If the battery voltage is too low to sustain the LED current, the 1.5x mode is automatically enabled. As the battery discharges and the voltage decays, the SP7680 automatically switches between modes to maintain a constant current to drive LEDs throughout the battery life.

### **Overtemperature Protection**

When the temperature of the SP7680 Rises above 170°C, the overtemperature protection circuitry turns off the output switches to prevent damage to the device. If the temperature drops back down below 145°C, the SP7680 automatically recovers and executes a soft start cycle.

### **Overvoltage Protection**

The SP7680 has overvoltage protection. In normal operation if the current-sinks are all open-circuited, the output voltage will rise only to the regulation voltage of 4.2V. When the current-sinks are no longer open-circuited, the device resumes normal operation.

### **Shorted LED Protection**

Shorted LED protection is provided. If the SP7680 detects a shorted LED the corresponding LED output will turn off (no current).

### **I<sup>2</sup>C interface**

The I<sup>2</sup>C interface allows a simple way to adjust each bank of channel currents in order to provide ultimate flexibility in driving LEDs. The SP7680 has five data registers which can be programmed serially via the I<sup>2</sup>C interface.

The STATUS register is used to enable/disable the part as well as for fault mode readback. The CNTRL register contains information regarding the state of each of the 7 individual LEDs. The final three registers contain information regarding the current level for the MAIN, SUB and AUX channels.

**TYPICAL PERFORMANCE CHARACTERISTICS**

$V_{IN} = 3.6V$ , Typical Application Circuit,  $T_A = 25^{\circ}C$  unless otherwise noted. For 7 LED curves, LED7 anode is connected to  $V_{OUT}$ , not  $V_{IN}$ .

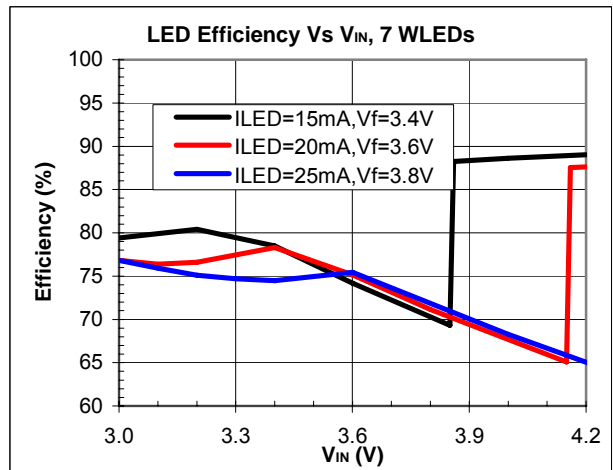
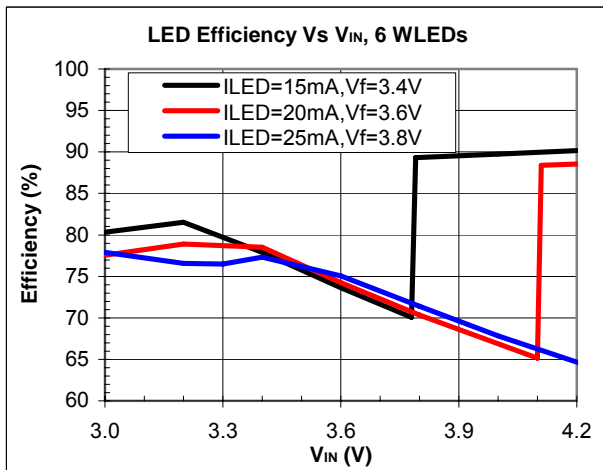
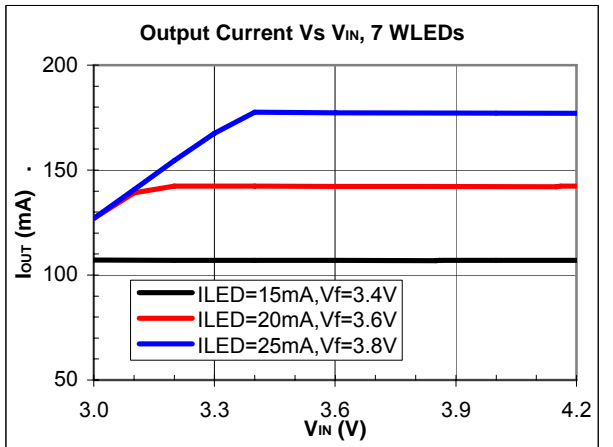
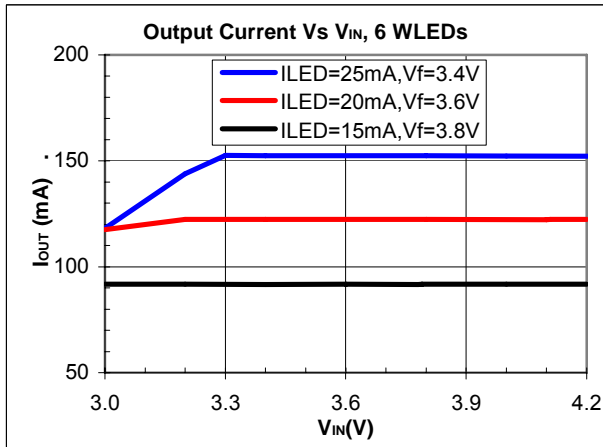
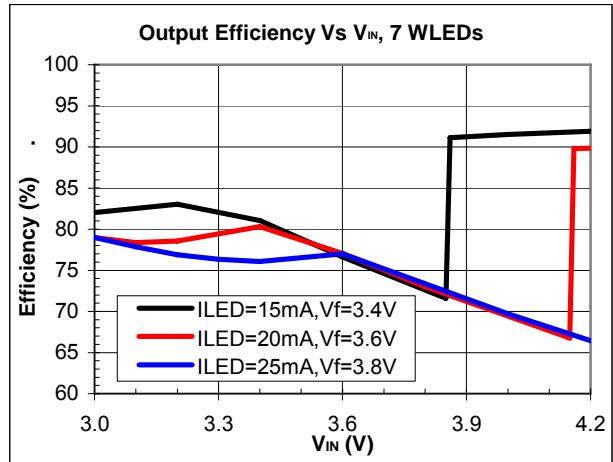
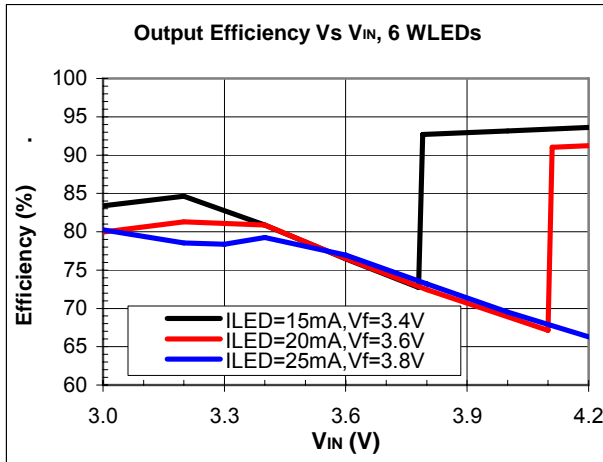

## TYPICAL PERFORMANCE CHARACTERISTICS

V<sub>IN</sub> = 3.6V, Typical Application Circuit, T<sub>A</sub> = 25°C unless otherwise noted.

**Scope Photo #1 Startup from Shutdown**

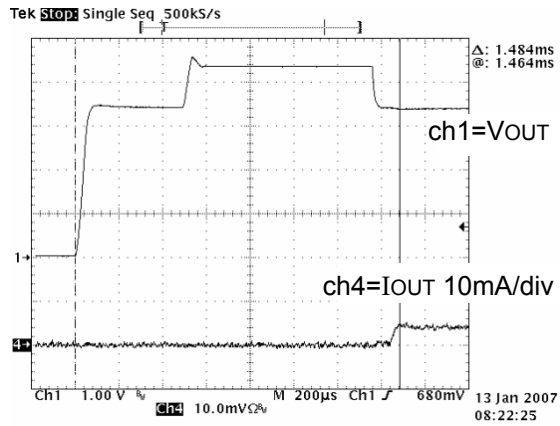

**Scope Photo #2 Soft start Interval (within 1X)**

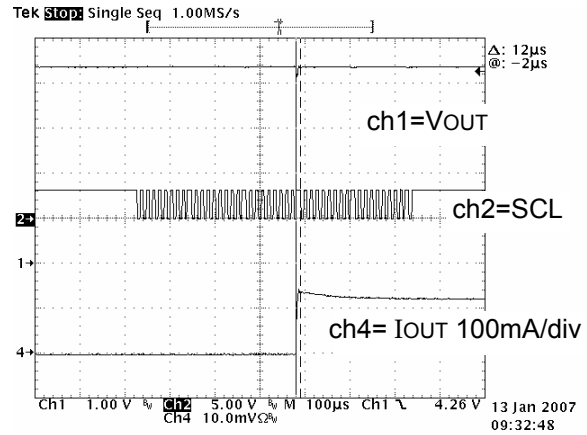

**Scope Photo #3 Soft start Interval (1X to 1.5X)**

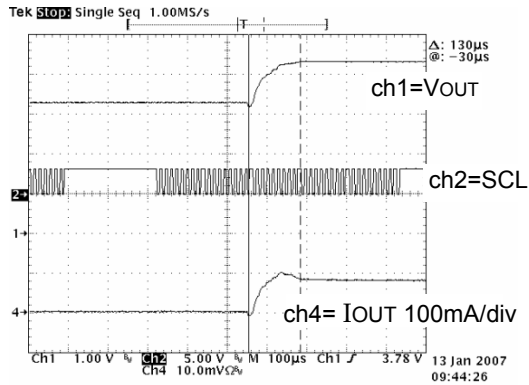

**Scope Photo #4 Voltage Ripple (1.5X Mode)**

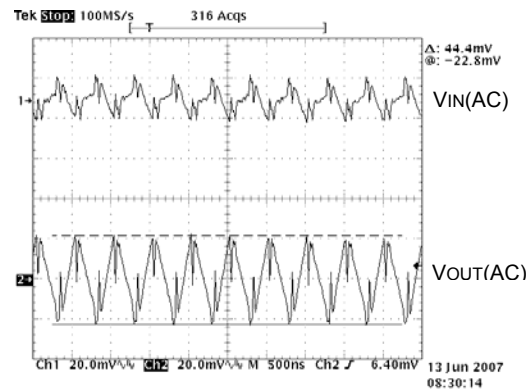

**Scope Photo #5 Startup in 1.5X Mode  
6 LEDs at 20mA**

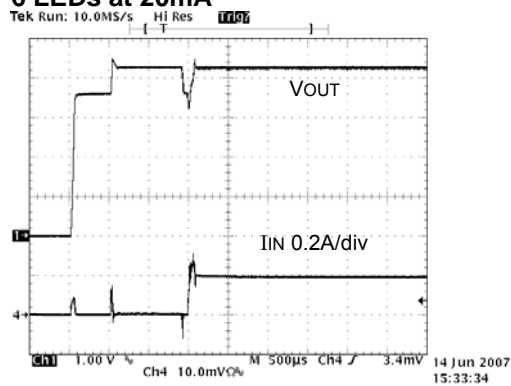

**Scope Photo #6 Startup in 1X Mode  
6 LEDs at 20mA**

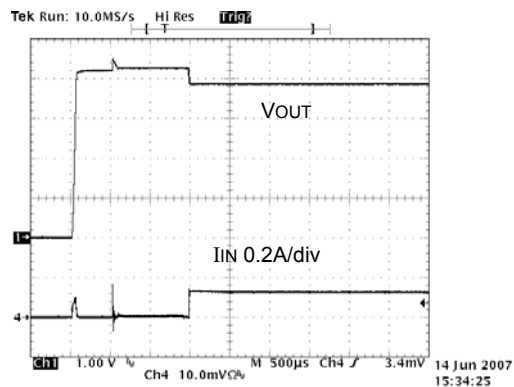

**I<sup>2</sup>C Specifications**

The I<sup>2</sup>C protocol defines any device that sends data to the bus as a transmitter and any device that reads the data as a receiver. The device that controls the data transfer is known as the

master and the other device as the slave. The master will always initiate a data transfer and will provide the serial clock for synchronization.

Data input format:

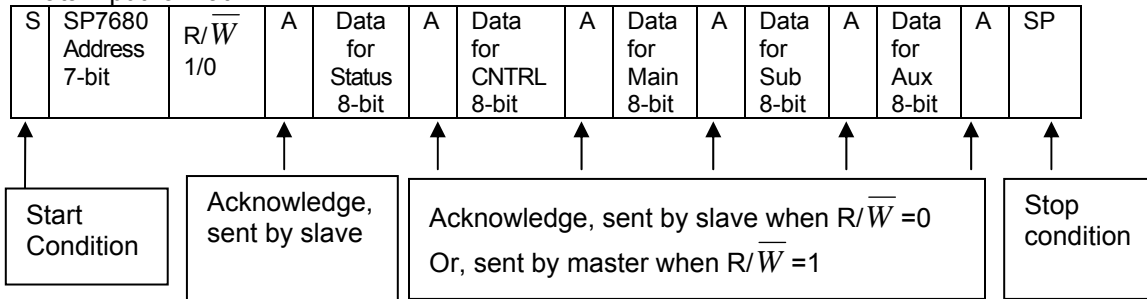

SP7680 I<sup>2</sup>C Slave Address Map: ( 7bit Default Address: 0x14)

Fuses		Device Address								R/W 1/0	7-bit address Hex
Fuse1	Fuse0	A7	A6	A5	A4	A3	A2	A1	A0	A7-A1	
0	0	0	0	1	0	1	0	0	0	0x14	
0	1	0	0	1	0	0	0	0	0	0x10	
1	0	0	0	1	1	1	0	0	0	0x1C	
1	1	0	0	1	1	0	0	0	0	0x18	

**Registers**

**I<sup>2</sup>C Serial Interface**

The SP7680 has five data registers which can be programmed serially via the I<sup>2</sup>C interface. The STATUS register is used to enable/disable the part as well as for fault mode readback. The CNTRL register contains information regarding the state of each of the 7 individual LEDs. The final three registers contain information regarding the current level for the MAIN, SUB and AUX channels.

The register bits are as follows:

STATUS	B7	B6	B5	B4	B3	B2	B1	B0
	WZ	WP	FLT	OVP	OVT	UVL	CPS	FCP
CNTRL	LED7	LED6	LED5	LED4	LED3	LED2	LED1	CPM
MAIN	D5	D4	D3	D2	D1	D0	dc	dc
SUB	D5	D4	D3	D2	D1	D0	dc	dc
AUX	D5	D4	D3	D2	D1	D0	dc	dc

**STATUS Register**

STATUS	B7	B6	B5	B4	B3	B2	B1	B0
	WZ	WP	FLT	OVP	OVT	UVL	CPS	FCP

In the STATUS register, b7 and b6 are used to enable/disable the SP7680. The following table defines the states for bits WZ and WP. These bits are used to put the SP7680 into shutdown, standby or active mode.

WZ	WP	State	Iq	LED drivers
0	0	Shutdown and reset registers to 00000000	0uA	Off
0	1	Shutdown - keep register contents	0uA	Off
1	0	Standby - keep register contents – bandgap and other analog circuits active, Vin shorted to Vout through internal switch	200uA	Off
1	1	Active	Active Iq	On

\*When WZ=0 and WP=0 all registers are set to zero.

Bits B5, B4, B3, B2 and B1 are for read back only. Bit B5 is held high whenever any kind of fault condition exists on the SP7680. Bits B4, B3 and B2 indicate the specific fault condition, over-voltage (B4=1), over-temp (B3=1) or undervoltage lockout (B2=1). B1 communicates the state of the charge pump, (B1=1 for 1.5x mode or B1=0 for 1x mode).

B0 of the STATUS register is used to select between automatic charge pump mode selection and forced charge pump mode selection. If B0 is low then the charge pump mode (1X or 1.5X) is automatically selected. If B0 is high then the charge pump is forced into either 1X mode or 1.5X mode depending upon B0 of the CNTRL register.

**Fault Conditions**

For all three fault conditions:

- Under Voltage Lockout
- Over Temperature Detection
- Over Voltage Protection

Upon entering any of these fault modes, the LED drivers should turn off but the register contents should remain unchanged with the exception of the fault mode readback bits of the status register. The WZ and WP bits of the status register should also remain unchanged. The microprocessor should not have to reset the SP7680 if it goes into fault mode. The chip should continuously monitor its fault indicators and when the fault condition is no longer present, normal operation can resume.

**CNTRL Register**

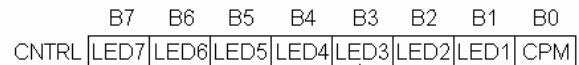

In the CNTRL register B1, B2, B3 and B4 are used to control the four MAIN LEDs, bits B5 and B6 are used for the two SUB LEDs, and B7 is used for the AUX LED. To enable an individual LED the corresponding bit is active high.

When B0 of the STATUS register is high, B0 of the CNTRL register is used to force the charge pump into 1X mode (CNTRL B0=low) or 1.5X mode (CNTRL B0=high). When B0 of the STATUS register is low then CNTRL B0 is ignored.

**MAIN, SUB and AUX registers**

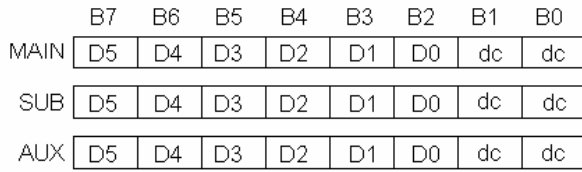

In the MAIN, SUB and AUX registers bits B7, B6, B5, B4, B3 and B2 represent the DAC codes D5-D0 used to set the LED current in the MAIN, SUB and AUX channels. Bits B1 and B0 are don't care. The following table lists the DAC codes and the corresponding current for each channel in mA; the table appears below and continues on the right column.

**Addressing and Writing Data to the SP7680**

To write data to the SP7680 the following data cycle must be obeyed:

[Slave Address with write bit][Data for STATUS][Data for CNTRL][Data for MAIN][Data for SUB][Data for AUX]

Six bytes are communicated each data cycle. All the settings will take effect right after the acknowledgement bit of the current data byte.

B7...B2	Main	Sub	Aux
010001	8.5	8.5	17.0
010010	9.0	9.0	18.0
010011	9.5	9.5	19.0
010100	10.0	10.0	20.0
010101	10.5	10.5	21.0
010110	11.0	11.0	22.0
010111	11.5	11.5	23.0
011000	12.0	12.0	24.0
011001	12.5	12.5	25.0
011010	13.0	13.0	26.0
011011	13.5	13.5	27.0
011100	14.0	14.0	28.0
011101	14.5	14.5	29.0
011110	15.0	15.0	30.0
011111	15.5	15.5	31.0
100000	16.0	16.0	32.0
100001	16.5	16.5	33.0
100010	17.0	17.0	34.0
100011	17.5	17.5	35.0
100100	18.0	18.0	36.0
100101	18.5	18.5	37.0
100110	19.0	19.0	38.0
100111	19.5	19.5	39.0
101000	20.0	20.0	40.0
101001	20.5	20.5	41.0
101010	21.0	21.0	42.0
101011	21.5	21.5	43.0
101100	22.0	22.0	44.0
101101	22.5	22.5	45.0
101110	23.0	23.0	46.0
101111	23.5	23.5	47.0
110000	24.0	24.0	48.0
110001	24.5	24.5	49.0
110010	25.0	25.0	50.0
110011	25.5	25.5	51.0
110100	26.0	26.0	52.0
110101	26.5	26.5	53.0
110110	27.0	27.0	54.0
110111	27.5	27.5	55.0
111000	28.0	28.0	56.0
111001	28.5	28.5	57.0
111010	29.0	29.0	58.0
111011	29.5	29.5	59.0
111100	30.0	30.0	60.0
111101	30.5	30.5	61.0
111110	31.0	31.0	62.0
111111	31.5	31.5	63.0

B7...B2	Main	Sub	Aux
000000	0	0	0
000001	0.031	0.031	0.031
000010	1.0	1.0	2.0
000011	1.5	1.5	3.0
000100	2.0	2.0	4.0
000101	2.5	2.5	5.0
000110	3.0	3.0	6.0
000111	3.5	3.5	7.0
001000	4.0	4.0	8.0
001001	4.5	4.5	9.0
001010	5.0	5.0	10.0
001011	5.5	5.5	11.0
001100	6.0	6.0	12.0
001101	6.5	6.5	13.0
001110	7.0	7.0	14.0
001111	7.5	7.5	15.0
010000	8.0	8.0	16.0

### LED Selection

The SP7680 is designed as a driver for backlight white LEDs, but is capable of driving other LED types with forward voltage specifications ranging from 2.0V to 3.8V. LED applications may include main and sub LCD display backlighting, camera photo-flash applications, color (RGB) LEDs, infrared (IR) diodes for remotes, and other loads benefiting from a controlled output current generated from a varying input voltage. Since the D1 to D6 output current-sinks are matched with negligible voltage dependence, the LED brightness will be matched regardless of the specific LED forward voltage (VF) levels. In flash applications, it may be necessary to drive high-VF type LEDs. The low dropout current-sinks in the SP7680 make it capable of driving main LEDs with forward voltages as high as 4.0V at full current from an input supply as low as 3.2V. LED current-sink inputs can be paralleled to drive high-current LEDs without complication.

### Device Switching Noise Performance

The SP7680 operates at a fixed frequency of approximately 2MHz to control noise and limit harmonics that can interfere with the RF operation of cellular telephone handsets or other communication devices. Back-injected noise appearing on the input pin of the charge pump is 20mV peak-to-peak, typically ten times less than inductor-based DC/DC boost converter white LED backlight solutions. The SP7680 soft-start feature prevents noise transient effects associated with inrush currents during startup of the charge pump circuit.

### Power Efficiency

The charge pump efficiency shown in the typical characteristic curves is shown for two cases. The first case is called output efficiency which is the power efficiency to the output as a ratio of the output voltage power to the input voltage power and expressed as a percentage. The second case is called LED efficiency and is the power efficiency to the LED outputs and is expressed as a ratio of the power to the LEDs to the input voltage power. The expressions are shown at the end of this section in their formulas. The first case is what is generally shown in competitors' datasheets and is shown

here for reference. The second case of LED power efficiency is included to show the user the true power delivered to the LEDs. As you can see in the curves, the LED efficiency is greatest when VIN is higher than the VF of the LEDs (and higher than the voltage required on the constant current-sink outputs of the LEDs) and that is when the SP7680 is in the 1x mode. When VIN is less than the VF (and less than the voltage required on the constant current-sink outputs of the LEDs) the SP7680 is in the 1.5x mode and in this mode the input current is 1.5 times the output current and therefore the efficiency will be reduced.

$$V_{OUT} \text{ efficiency} = \frac{V_{OUT} \cdot I_{OUT}}{(V_{IN} \cdot I_{IN})} \cdot 100\%$$

$$\text{LED efficiency} = \frac{(V_{OUT} - V_{LED}) \cdot I_{OUT}}{(V_{IN} \cdot I_{IN})} \cdot 100\%$$

Refer to the Typical Characteristics section of this document for measured plots of efficiency versus input voltage and output load current versus input voltage for given LED output current options.

### Capacitor Characteristics

Ceramic composition capacitors are highly recommended over all other types of capacitors for use with the SP7680. Ceramic capacitors offer many advantages over their tantalum and aluminum electrolytic counterparts. A ceramic capacitor has very low ESR, is lower in cost, has a smaller PCB footprint, and is non-polarized. Low ESR ceramic capacitors help to maximize charge pump transient response. Since ceramic capacitors are non-polarized, they are not prone to incorrect connection damage.

### Equivalent Series Resistance (ESR)

ESR is an important characteristic to consider when selecting a capacitor. ESR is a resistance internal to a capacitor that is caused by the leads, internal connections, size or area, material composition, and ambient temperature. Capacitor ESR is typically measured in milliohms for ceramic capacitors and can range to more than several Ohms for tantalum or aluminum electrolytic capacitors.

**Ceramic Capacitor Materials**

Capacitors with large output values are typically composed of X7R, X5R, Z5U, or Y5V dielectric materials, but Z5U and Y5V are not recommended since they have a large change in value with temperature. X5R and X7R capacitors are recommended since they are relatively low in cost and their output value changes with temperature are relatively small.

**Capacitor Selection**

Careful selection of the four external capacitors C<sub>IN</sub>, C<sub>1</sub>, C<sub>2</sub>, and C<sub>OUT</sub> is important because they will affect turn-on time, output ripple, and transient performance. Optimum performance will be obtained when low equivalent series resistance (ESR) ceramic capacitors are used. In general, low ESR may be defined as less than 100mΩ. A value of 2.2μF for the input and 1μF for the output capacitor is sufficient for most

applications. The fly capacitors C<sub>1</sub> and C<sub>2</sub> can be 0.47μF for most applications. For applications with all 7 LED drivers used and driven to 20mA or more, it is advisable to use a 2.2μF input capacitor in order to reduce the input ripple as seen by the battery. In very noise sensitive applications, the input capacitor can even be increased to 4.7μF. If the LED current-sinks are only programmed for low current levels, or if the application is not very noise sensitive, then a 1μF input capacitor may be used. See table 1 for capacitor selection.

**Thermal Protection**

The SP7680 has a thermal protection circuit that will shut down the internal LDO and charge pump if the die temperature rises above the thermal limit, and will restart when the die temperature drops about 25°C below the thermal limit.

Manufacturers/ Website	Part Number	Capacitance/ Voltage	Capacitor Size/Type/Thickness	ESR at 100kHz
TDK/www.tdk.com	C1005X5R0J474K	0.47uF/6.3V	0402/X5R/0.55mm	0.05
TDK/www.tdk.com	C1005X5R0J105K	1uF/6.3V	0402/X5R/0.55mm	0.03
TDK/www.tdk.com	C1608X5R0J225K	2.2uF/6.3V	0603/X5R/0.9mm	0.03
TDK/www.tdk.com	C1608X5R0J475K	4.7uF/6.3V	0603/X5R/0.9mm	0.02
Murata/www.murata.com	GRM155R60J474KE19	0.47uF/6.3V	0402/X5R/0.55mm	0.05
Murata/www.murata.com	GRM155R60J105KE19	1uF/6.3V	0402/X5R/0.55mm	0.03
Murata/www.murata.com	GRM185R60J225KE26	2.2uF/6.3V	0603/X5R/0.55mm	0.03
Murata/www.murata.com	GRM188R60J475KE19	4.7uF/6.3V	0603/X5R/0.8mm	0.02

**Table 1: SP7680 Capacitor Selection**

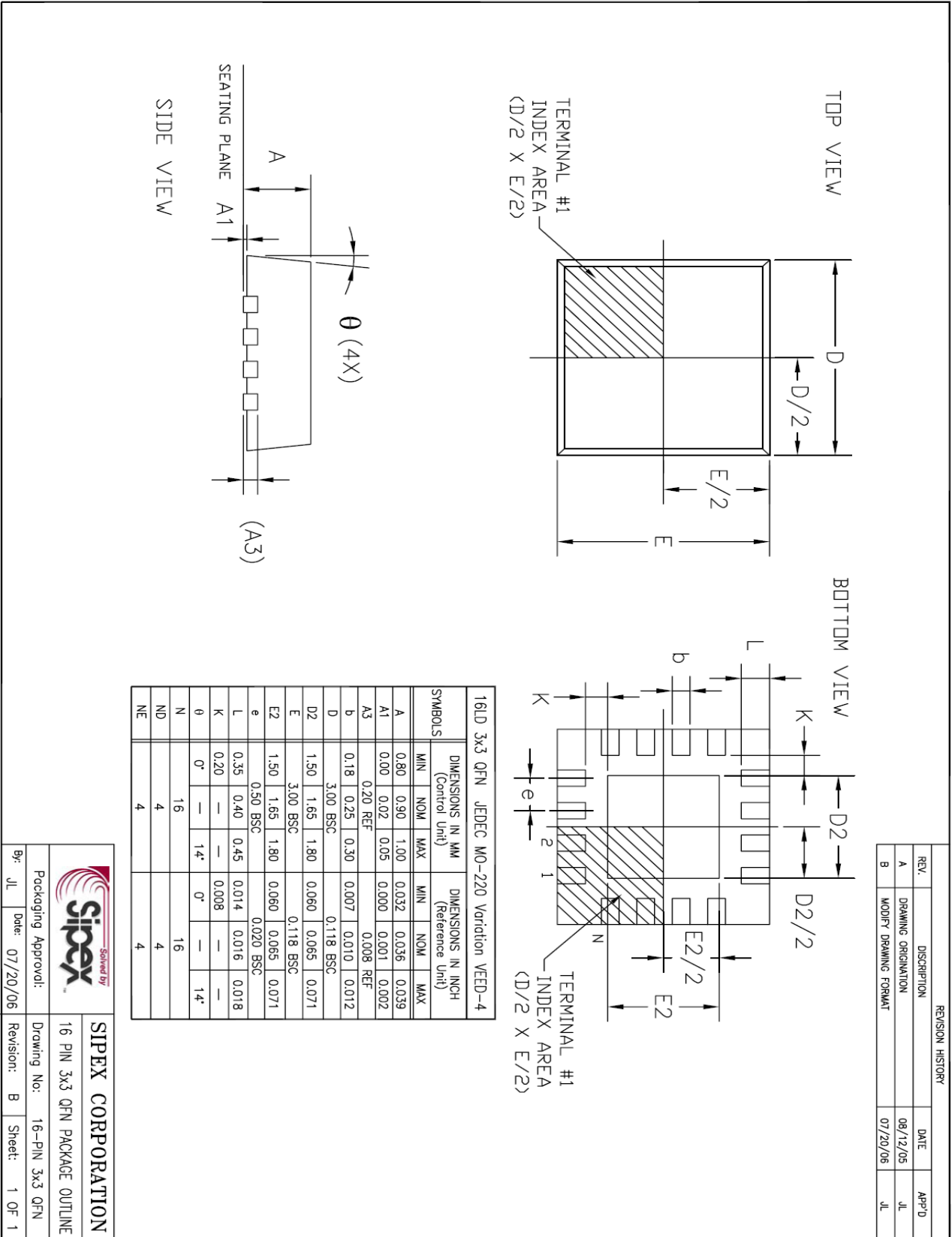

REV.	DESCRIPTION	DATE	APP'D
A	DRAWING ORIENTATION	08/12/05	JL
B	MODIFY DRAWING FORMAT	07/20/06	JL

**SIPLEX CORPORATION**

16 PIN 3x3 QFN PACKAGE OUTLINE

By: JL Date: 07/20/06

Drawing No: 16-PIN 3x3 QFN

Revision: B Sheet: 1 OF 1

---

## ORDERING INFORMATION

Part Number	Status	Min Temp °C	Max Temp °C	RoHS	Theta JA °C/W	MSL Level	Pack Type	Quantity	Package
SP7680ER1-L	Active	-40	85	Yes	33.3	L3 @ 260°C	Canister	Any	<a href="#">3x3 16 Pin QFN</a>
SP7680ER1-L/TR	Active	-40	85	Yes	33.3	L3 @ 260°C	Tape & Reel	3000	<a href="#">3x3 16 Pin QFN</a>
SP7680EB	Active	-40	85	Not Applicable to Eval Board					<a href="#">Board</a>

For further assistance:

Email: [Sipexsupport@sipex.com](mailto:Sipexsupport@sipex.com)  
WWW Support page: <http://www.sipex.com/content.aspx?p=support>  
Sipex Application Notes: <http://www.sipex.com/applicationNotes.aspx>



### Sipex Corporation

Headquarters and  
Sales Office  
233 South Hillview Drive  
Milpitas, CA95035  
tel: (408) 934-7500  
FAX: (408) 935-7600

Sipex Corporation reserves the right to make changes to any products described herein. Sipex does not assume any liability arising out of the application or use of any product or circuit described herein; neither does it convey any license under its patent rights nor the rights of others.